



## PERFORMANCE 5 UPP

**POWER RANGE: 545 - 520 W**

The SunPower Performance 5 UPP panel is engineered to meet the unique needs of solar power plants. Bifacial power generation and G12 (210mm) cell technology combine to maximise power density, while its framed glass/glass construction offers greater durability for extended panel life.

Backed by an industry-leading warranty and an estimated 35-year useful life,<sup>1</sup> SunPower Performance panels wrap conventional front contact cells with 35 years of materials, engineering and manufacturing expertise to mitigate the reliability challenges of Conventional Panel design.

### Engineered for Performance

- Smaller cells stay cooler when shaded, extending panel life<sup>3</sup>
- Proprietary encapsulant minimizes degradation from environmental exposure
- Conductive adhesive defends against daily temperature swings
- Redundant cell connections create flexible paths for continuous electricity flow

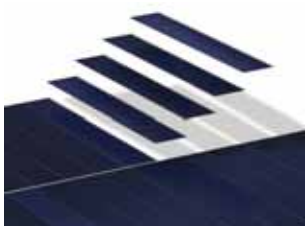

### Durability that Translates to More Energy

Engineered to stand up to environmental stresses such as shading, daily temperature swings and high humidity, the SunPower Performance 5 UPP is a high power panel uniquely suited for power plant EPCs and developers looking to maximize energy production.

### A Track Record of Innovation Leadership

SunPower Performance panels represent the most deployed shingled cell panel in the industry—innovation protected by a growing portfolio of patents worldwide.<sup>2</sup>



4+ GW  
Deployed



60+  
Countries



90+  
Patents

### A Better Product. A Better Warranty.

SunPower Performance 5 UPP panel is backed by the SunPower Performance UPP panel warranty providing 12-year product and 30-year power coverage.

- Year 1 Minimum Warranted Power Output 98.0%
- Maximum Annual Degradation 0.45%
- Year 30 Warranted Power Output 85.0%

PERFORMANCE 5 UPP POWER: 545 – 520 W - PRELIMINARY

Electrical Data, Front STC Characteristics <sup>4</sup>						
Model	SPR-P5-545-UPP	SPR-P5-540-UPP	SPR-P5-535-UPP	SPR-P5-530-UPP	SPR-P5-525-UPP	SPR-P5-520-UPP
Nominal Power (P <sub>nom</sub> ) <sup>4</sup>	545 W	540 W	535 W	530 W	525 W	520 W
Power Tolerance	+3/0%	+3/0%	+3/0%	+3/0%	+3/0%	+3/0%
Efficiency	21.0%	20.8%	20.6%	20.4%	20.2%	20.0%
Rated Voltage (V <sub>mpp</sub> )	39.4 V	39.1 V	38.8 V	38.5 V	38.2 V	37.9 V
Rated Current (I <sub>mpp</sub> )	13.85 A	13.83 A	13.81 A	13.78 A	13.76 A	13.74 A
Open-Circuit Voltage (V <sub>oc</sub> ) (+/-3%)	47.8 V	47.6 V	47.4 V	47.1 V	46.8 V	46.5 V
Short-Circuit Current (I <sub>sc</sub> ) (+/-3%)	14.78 A	14.76 A	14.74 A	14.71 A	14.66 A	14.64 A
Maximum System Voltage	1500 V IEC					
Maximum Series Fuse	25 A					
Power Temp. Coef.	-0.34% / °C					
Voltage Temp. Coef.	-0.28% / °C					
Current Temp. Coef.	0.06% / °C					

Bifacial Characteristics						
Bifaciality (φP <sub>max</sub> )	≥65%					
P <sub>max</sub> BiF05	563 W	558 W	552 W	547 W	542 W	537 W
I <sub>sc</sub> BiF05	15.26 A	15.24 A	15.22 A	15.19 A	15.14 A	15.12 A
P <sub>max</sub> BiF10	580 W	575 W	570 W	564 W	559 W	554 W
I <sub>sc</sub> BiF10	15.74 A	15.72 A	15.7 A	15.67 A	15.61 A	15.59 A
P <sub>max</sub> BiF20	616 W	610 W	605 W	599 W	593 W	588 W
I <sub>sc</sub> BiF20	16.7 A	16.68 A	16.66 A	16.62 A	16.57 A	16.54 A

Tests And Certifications (Pending)	
Standard Tests <sup>5</sup>	IEC 61215, IEC 61730 Rated to 1500 V
Quality Certs	ISO 9001:2008, ISO 14001:2004
EHS Compliance	OHSAS 18001:2007, Recycling Scheme
Ammonia Test	IEC 62716
Desert Test	MIL-STD-810G
Salt Spray Test	IEC 61701 (maximum severity)
LeTID Test <sup>6</sup>	IEC 61215 (MQT 23.1 LeTID detection) draft standard
PID Test	IEC 62804
Available Listings <sup>7</sup>	TUV

Operating Condition And Mechanical Data	
Temperature	-40°C to +85°C
Impact Resistance	25 mm diameter hail at 23 m/s
Solar Cells	Monocrystalline PERC
Tempered Glass	High-transmission tempered anti-reflective
Junction Box	IP-67, Renhe ZJRH 05-8 or Zerun Z4S or Stäubli Evo2, 3 bypass diodes
Weight	31.5 kg
Max. Load	Wind: 2400 Pa, 245 kg/m <sup>2</sup> front & back Snow: 5400 Pa, 550 kg/m <sup>2</sup> front
Frame	Class 2 silver anodized

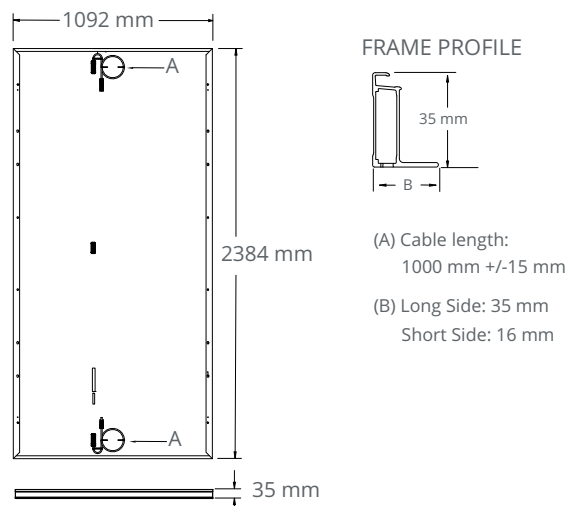

Please read the safety and installation guide.

1 Performance panels expected useful life of 35 years. Source: "SunPower P-Series Technology Technical Review," Leidos Independent Engineer Report, 2016.

2 Based on shipments as of Q2-2020.

3 SunPower Performance Series – Thermal Performance, Z.Campeau 2016.

4 Measured at Standard Test Conditions (STC): irradiance of 1000 W/m<sup>2</sup>, AM 1.5, and cell temperature 25° C.

5 Class C fire rating per IEC 61730.

6 Fraunhofer CSP LID Sensitivity according to IEC 61215 (MQT 23.1 LeTID detection), 0.5% power loss at 700 hours.

7. Cert only covers front side performance.

Designed in the U.S.A. by SunPower Corporation  
Assembled in China

Specifications included in this datasheet are subject to change without notice.

© 2020 Maxeon Solar Technologies, Ltd. All Rights Reserved. View warranty, patent and trademark information at maxeon.com/legal.